

PLEASE READ

This manual is provided as a free service by Projector.com.

We are in no way responsible for the contents of the manual. We do not guarantee its accuracy and we do not make any claim of copyright. The copyright remains the property of their respective owners.

ABOUT PROJECTOR.COM

Projector.com (<http://www.projector.com>) is your review and buying guide resource for DLP and LCD video projectors.

Visit the site to read the latest projector news and reviews, read and comment on projector specifications, download user manuals and much more.

DUKANE
ImagePro 8747
Projector
USERS GUIDE



MODEL 28A8747

FCC Warning

This equipment has been tested and found to comply with the limits for a Class A digital device, pursuant to part 15 of the FCC Rules. These limits are designed to provide reasonable protection against harmful interference when the equipment is operated in a commercial environment. This equipment generates, uses, and can radiate radio frequency energy and, if not installed and used in accordance with the instruction manual, may cause harmful interference to radio communications. Operation of this equipment in a residential area is likely to cause harmful interference in which case the user will be required to correct the interference at his own expense.

Canada

This Class A digital apparatus complies with Canadian ICES-003.
Cet appareil numérique de la classe A est conforme à la norme NMB-003 du Canada.

Safety Certifications

UL, CUL, TÜV, NOM, IRAM

EN 55022 Warning

This is a Class A product. In a domestic environment it may cause radio interference, in which case the user may be required to take adequate measures.

Trademarks

Apple, Macintosh, and PowerBook are trademarks or registered trademarks of Apple Computer, Inc. IBM and PS/2 are trademarks or registered trademarks of International Business Machines, Inc. Microsoft, PowerPoint, and Windows are trademarks or registered trademarks of Microsoft Corporation. Digital Light Processing is a trademark or registered trademark of Texas Instruments. InFocus and LP are trademarks or registered trademarks of InFocus Corporation.

TABLE OF CONTENTS

Safety Instructions	iii
Introduction	1
Image Resolution	1
Compatibility	1
Unpacking the Projector	1
Usage Guidelines	3
If You Need Assistance	4
Warranty	4
Setting up the Projector	5
Connecting a Computer	7
Connecting a Video Player	8
Powering up the Projector and Adjusting the Image	9
Turning Off the Projector	13
Using the Projector	15
Basic Image Adjustment	15
Adjusting the Projector	15
Using the Remote Control	17
Using the Keypad and Remote Buttons	18
Using the On-Screen Menus	20
Display Menu	21
Image Menu for Computer Sources	23
Image Menu for Video Sources	25
Control Menu	26
Advanced Menu	27
Language Menu	28
Status Menu	29

Maintenance & Troubleshooting	31
Cleaning the Lens	31
Replacing the Projection Lamp	31
Cleaning the Projection Lamp Filter Screens	34
Replacing the Batteries in the Remote Control	35
Using the Security Lock	35
Troubleshooting	36
Appendix	41
Specifications	41
Accessories	42
Portable and Laptop Activation Chart	44
Using Video Mirroring with a PowerBook Computer	49
Projected Image Size	50
Index	51

SAFETY INSTRUCTIONS

Please read and follow all safety instructions provided BEFORE using your new projector. Failure to comply with safety instructions may result in fire, electrical shock, or personal injury and may damage or impair protection provided by equipment. Please save all safety instructions.

Safety Definitions:

- **Warning:** Statements identify conditions or practices that could result in personal injury.
- **Caution:** Statements identify conditions or practices that could result in damage to your equipment.

Safety Symbols:



Attention: For information about usage of a feature, please refer to the User's Guide.



Warning: Hot surface. Do not touch.



An arrow pointing to the lamp door on the projector.

Safety Terms:

- **Warning:** Don't look directly into the lens when the projector is turned on.
 - **Warning:** To replace the lamp, turn the projector off and unplug the power cord. To avoid burns, wait 30 minutes before opening the lamp access grill. Follow all instructions provided in this User's Guide.
 - **Warning:** Please use the power cord provided. This projector employs double insulation which does not require an Earth ground (third prong on power cord plug).
- **Warning:** Refer all service to qualified service personnel. Servicing your own projector will void the warranty. See the following page for the customer service contact information.

- **Caution:** Don't block ventilation openings.
- **Caution:** Don't set liquids on the projector. Spilled liquids may damage your projector.
- **Caution:** Don't place the projector on a hot surface or in direct sunlight.
- **Caution:** Do not drop the projector. Transport the projector in an Dukane-approved case.

Important Operating Considerations

Do not place the projector on a tablecloth or other soft covering that may block the vents. In the unlikely event of the bulb rupturing, thoroughly clean the area in front of the projector and discard any edible items placed in that area.

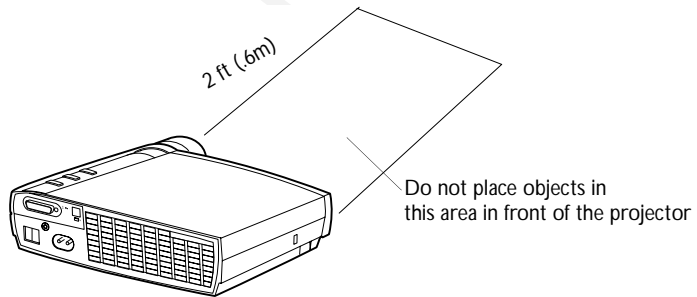

Customer Service

If you need assistance, call Dukane Customer Service at:
630-584-2300 or Toll Free at: 1-800-676-2487

INTRODUCTION

The Dukane Image Pro™8747 digital Projector is specifically designed for the mobile presenter. It generates crisp, clear images using Digital Light Processing™ (DLP) technology, and features an M1-DA type DVI connector for easy, built-in digital/analog and USB connectivity. It is easy to connect, easy to use, easy to transport, and easy to maintain.

Image Resolution

The XGA resolution of the ImagePro 8747 projector image is 1024 X 768. The projector is compatible with screen resolutions up to 1280x1024. If your computer's screen resolution is higher than 1280x1024, reset it to a lower resolution before you connect the projector.

Compatibility

The projector is compatible with a wide variety of computers and video devices, including:

- IBM-compatible computers, including laptops, up to 1280x1024 resolution.
- Apple® Macintosh® and PowerBook® computers up to 1280x1024 resolution.
- Most standard VCRs, DVD players, HDTV sources, camcorders and laser disc players.

Unpacking the Projector

The projector comes with the items shown in Figure 1. Check to make sure all are included. **Contact your Dukane dealer immediately if anything is missing.**



.....
NOTE: The ImagePro 8747 automatically expands 640x480 and 800x600 images to 1024x768. You can display these images at their native resolutions using the Resize option in the Image menu. See page 19 for more information.



.....
NOTE: The projector is compatible with 1080i and 720P HDTV formats.

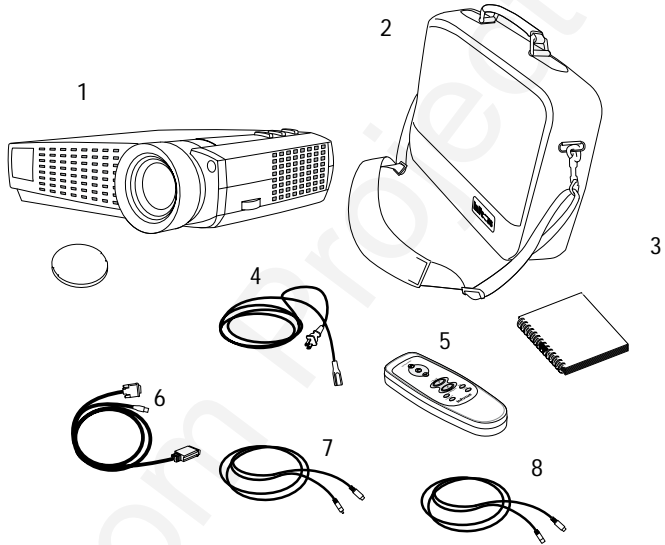

FIGURE 1

Shipping box contents

- | | |
|---|--------------------------|
| 1. ImagePro 8747 digital projector + lens cap | 5. Remote control |
| 2. Soft carry case | 6. Analog computer cable |
| 3. User's Guide | 7. Composite video cable |
| 4. Power cord | 8. S-video cable |

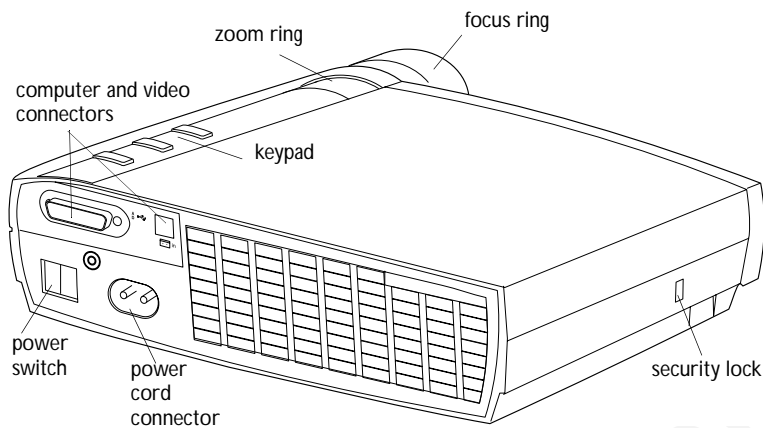

FIGURE 2

Side view of projector

Usage Guidelines

- Do not look directly into the projection lens when the projector is turned on. The bright light may harm your eyes.
- Do not block the grills on the projector. Restricting the air flow can cause it to overheat and turn off. If this happens, you must wait a minute before attempting to turn it back on.
- Handle the projector as you would any product with glass components. Be especially careful not to drop it.
- Avoid leaving the projector in direct sunlight or extreme cold for extended periods of time. If this happens, allow it to reach room temperature before use.
- Transport the projector in a vendor-approved hard or soft case.

If You Need Assistance

The first place to look for help is in this manual. Be sure to check the guidelines in "Troubleshooting" on page 36.

If those sources don't answer your question, call your Dukane dealer. You can also call Dukane Customer Service directly at: **630-584-2300 or Toll Free at: 1-800-676-2487**

Our World Wide Web address is <http://www.dukane.com>.

Warranty

This product is backed by a limited five year warranty. The Details of the warranty are printed at the back of this manual.
Dukane

When sending your projector in for repair, Dukane recommends shipping the unit in its original packing material, or having a professional packaging company pack the unit for shipping. Do not ship your projector in the enclosed soft case. Please insure your shipment for its full value.

SETTING UP THE PROJECTOR

- 1 Place the projector on a flat surface.
 - The projector must be within 10 feet (3 m) of your power source and within 6 feet (1.8 m) of your computer.
 - If you want to project from behind a translucent screen, set up the projector behind your screen. See “Rear Projection” on page 27 to reverse the image.
- 2 Position the projector the desired distance from the screen.
 - If the image is too big or too small, use the zoom ring to adjust the size or move the projector forward or backward. Figure 3 shows three projected image sizes. For more information about image size, see “Projected Image Size” on page 51.

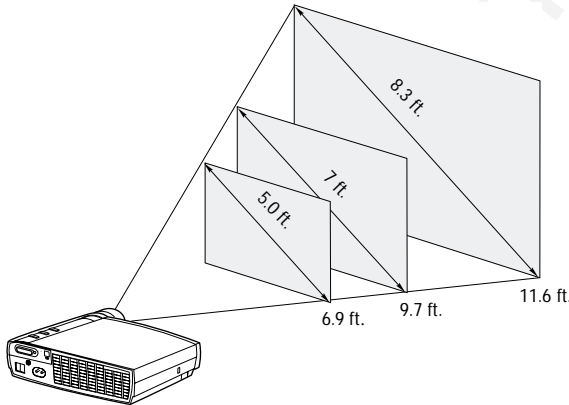

FIGURE 3

Projected image size at minimum zoom

- 3 Make sure the projector and the computer are turned off.



NOTE: Before you continue, make sure the projector and all other equipment is turned off. If you're connecting a computer, make sure the distance between it and the projector is 6 feet or less.

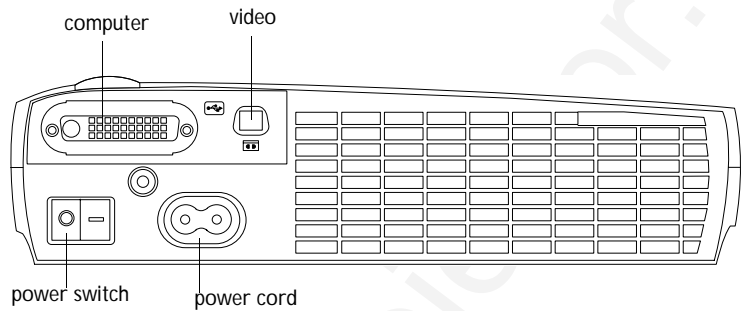

FIGURE 4

Connector panel

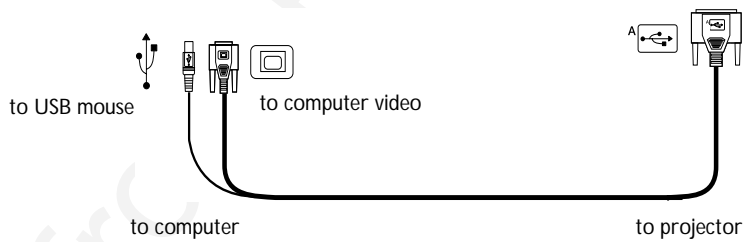

FIGURE 5

Computer cable



NOTE: If you are connecting an older Macintosh computer that does not have a 15-pin connector, you must use a Mac adaptor between the computer and the projector. See "Optional Accessories" on page 51.

Connecting a Computer

The projector ships with an analog computer cable. If your computer has a digital output, you can order the optional digital computer cable. Using a digital source generates the highest quality and brightest image possible. See “Optional Accessories” on page 43.

- 1 Plug the end of the computer cable with one cable into the connector on the projector.
- 2 Plug the blue end of the computer cable into the video connector on your computer.
- 3 If you want to advance slides in a PowerPoint™ presentation using the remote, plug the USB cable into the USB mouse connector on your computer. To use the USB functionality, you must install the USB drivers. See page 11.

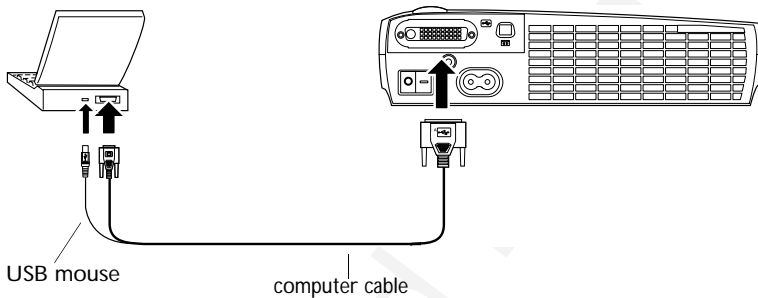

FIGURE 6

Connecting the projector to a computer

Now you're ready to power up the projector and your laptop. Skip to “Powering up the Projector and Adjusting the Image” on page 9.



NOTE: Many laptop computers do not automatically turn on their external video port when a secondary display device such as a projector is connected. Refer to your computer manual for the command that activates the external video port. Activation commands for some laptop computers are listed in the Appendix of this manual on page 44 and in the Service section of our website.



NOTE: The USB mouse is supported for use with Windows 98, Windows 2000, and Apple OS 8.5 and higher only.



NOTE: You do not need to restart your computer after connecting a USB mouse to use it.



NOTE: HDTV sources must be connected to the projector using the computer cable (not the video cable). See the previous pages for details on connecting this cable.

Connecting a Video Player

If your video player uses a round, one-prong composite video connector, use the composite video cable. If your video player uses a round, four-prong S-video connector, use the S-video cable. S-video generates a higher quality image.

- 1 Plug the composite video cable's round yellow connector into the "video-out" connector on your video player (Figure 7). This connector may be labeled "To Monitor."
 - If you're using an S-video cable, connect the round black connector to the "S-video out" connector on the video player.
- 2 Plug the square yellow connector into the video connector on the projector.

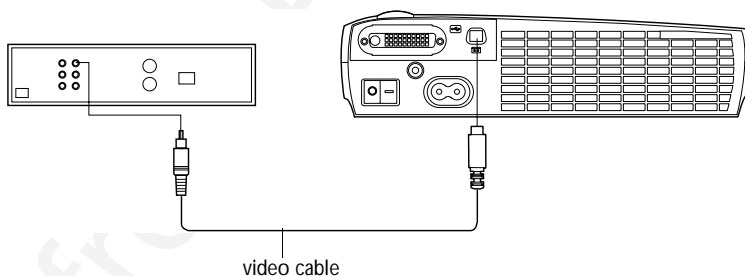

FIGURE 7

Connecting the projector to a video player



CAUTION: Your video player may also have a "Video Out" connector for a coaxial cable connection. DO NOT use this to connect to the projector.

The projector is compatible with these major broadcast video standards: NTSC, NTSC 4.43, PAL, PAL-M, PAL-N, PAL-60, and SECAM. It automatically adjusts to optimize its performance for the incoming video.

Powering up the Projector and Adjusting the Image

- 1 Remove the lens cap.
- 2 Plug the power cord into the back of the projector, then plug it into your electrical outlet. A surge-protected power strip is recommended.
- 3 Press the Power switch on the back of the projector.
 - The fans start to run, the LED on the top of the projector (Figure 11 on page 18) lights green, and the InFocus startup screen appears. It takes about one minute for the image to achieve full brightness.
- 4 If you connected a video player, turn it on.
 - The video image should display on the projection screen. If it doesn't, press the **source** button on the keypad (page 18) or the **video** button on the remote to display your video image.
- 5 If you connected a computer, turn it on.

For Windows 98:

- a The first time you connect a particular computer to the projector, the computer recognizes the projector as “new hardware” and the Add New Hardware Wizard appears. Follow these instructions to use the Wizard to load the correct driver (which was installed with your Windows operating system).



NOTE: Always use the power cord that shipped with the projector.



NOTE: If you are using a Macintosh computer, please refer to page x for driver installation instructions.



NOTE: With some computers, the order in which you power up the equipment is very important. Most computers should be turned on last, after all other peripherals have been turned on. Refer to your computer's documentation.



Click Next. Make sure “Search for the best driver” is selected, then click Next.



Uncheck any checked boxes, then click Next. Windows automatically locates the driver. If this driver has been removed, reload the driver using your Windows operating system CD.



When Windows finds the driver, you are ready to install it. Click Next.



Click Finish when installation is complete.

- b** If you connected the USB cable (page 7), the Add New Hardware Wizard appears again. Drivers must be installed to use the USB functionality. The Wizard is launched four times. The first time it detects a USB Composite Device, the second time a USB Human Interface Device (for the keyboard), the third time a USB Human Interface Device (for the mouse), and the fourth cancel the final Wizard.



NOTE: The USB mouse is supported for use with Windows 98, Windows 2000, and Apple OS 8.5 and higher only. Windows NT is not supported.

For Windows 2000 and Windows ME:

- a The USB drivers for mouse control are automatically installed.

For a Macintosh computer running Mac OS X:

- a A Mac OS X driver and Control Panel will be available soon. The USB driver on the CD will not work in the Classic Mac OS environment provided in Mac OS X. You should boot OS 9.1 and follow the Mac OS 9.1 instructions.

For a Macintosh computer running Mac OS 9.1:

- a A dialog box appears stating that software is needed for the USB device. Click Cancel. We recommend installing Projector Manager software.
- 6 The computer image should display on the projection screen. If it doesn't, press the **source** button on the keypad or the **data** button on the remote to display your computer's image.
- Make sure your laptop's external video port is activated; see "Portable and Laptop Activation Chart" on page 44 for details.
 - If necessary, make adjustments to the image using the projector's on-screen menus. To open the menus, press the **menu/select** button on the keypad or remote. For more information about the menus, see page 20.

Turning Off the Projector

To turn off the projector, press the Power switch. If you want to turn the lamp back on, you must allow 90 seconds for the lamp to cool. The lamp won't light if it's too hot.



.....
NOTE: To maximize lamp life, allow the projector to run for at least five minutes before turning it off.

USING THE PROJECTOR

This section describes how to use and make adjustments to the projector. It also provides a reference to the keypad and remote buttons and the options available from the on-screen menus.

Basic Image Adjustment

- 1 Make sure you have powered up your equipment in the right order (page 9).
- 2 If the image doesn't display completely, zoom the image (page 15), adjust the height of the projector (page 16) or center the image by adjusting its horizontal or vertical position (page 24). Be sure the projector is at a 90 degree angle to the screen.
- 3 If the image is out of focus, rotate the focus lens (page 15).
- 4 If the colors don't look right, adjust the brightness, contrast, tint, or color (page 21).

Adjusting the Projector

To focus the image, rotate the focus ring (Figure 8) until the image is clear. To zoom the image, rotate the zoom ring. This adjusts the image size.

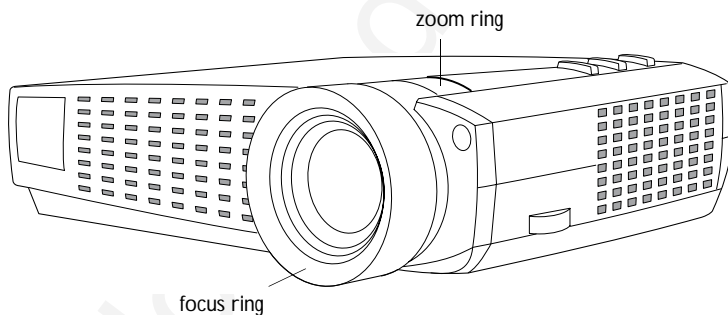

FIGURE 8

Focus ring and zoom ring



NOTE: To obtain the best overall focus quality, open the menu and focus on the text. This will ensure that the best overall image quality is achieved.

The projector is equipped with a self-locking, quick-release elevator foot and button.

To raise the projector:

- 1 Press and hold the elevator button (Figure 9).
- 2 Raise the projector to the height you want, then release the button to lock the elevator foot into position.

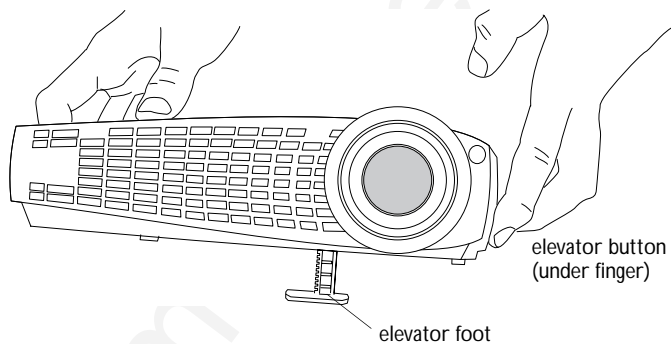

FIGURE 9

Adjusting the height of the projector

Using the Remote Control

To use the forward and back buttons on the remote to advance slides in PowerPoint, you must connect the USB mouse connector on the computer cable to the computer. See page 7 for details.

Point the remote control at the projection screen or at the front of the projector (not at the computer). The range for optimum operation is about 25 feet. If you point the remote at the projection screen, the distance to the screen and back to the projector must be less than or equal to 25 feet. For best results, point the remote directly at the projector.

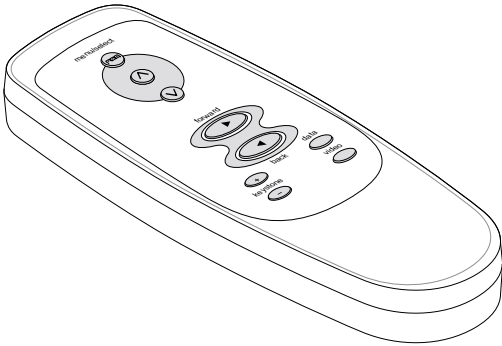

FIGURE 10

Remote control

Using the Keypad and Remote Buttons

While the menus are displayed, the **source** and **reset** buttons on the keypad and the up and down arrow buttons on the remote act as menu navigation and adjustment buttons and the **menu/select** button acts as a select button. See “Using the On-Screen Menus” on page 20 for details.

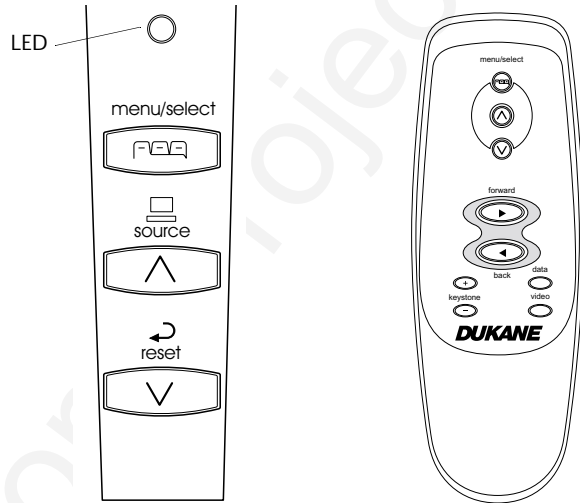

FIGURE 11
Keypad and remote buttons



NOTE: If you have turned Auto Source off (page 26), you may need to press the source button more than once to display an active source. The sources switch in this order: data analog, data digital, S-video, and composite video.

Menu/select

Press the **menu/select** button to open the on-screen menus. Press **menu/select** again (while Exit is highlighted) to close the menus. (The menus automatically close after 30 seconds if no buttons are pressed.) When you close the menus, the projector saves any changes you made. For more information about the on-screen menus, see page 20.

Source (keypad only) or Data and Video (remote only)

When you have more than one source (computer and video) connected to the projector, select between them by pressing the **source** button on the keypad or the **data** or **video** button on the remote.

Reset ↶ (keypad only)

This resynchs the computer to the projector.

Keystone + - (remote only)

Use this feature to adjust the image vertically and make a squarer image.

- 1 Press the **keystone +** button to reduce the upper part of the image, and press the **keystone -** button to reduce the lower part. You can also adjust keystone from the Display menu (see page 21 for details on the menu).

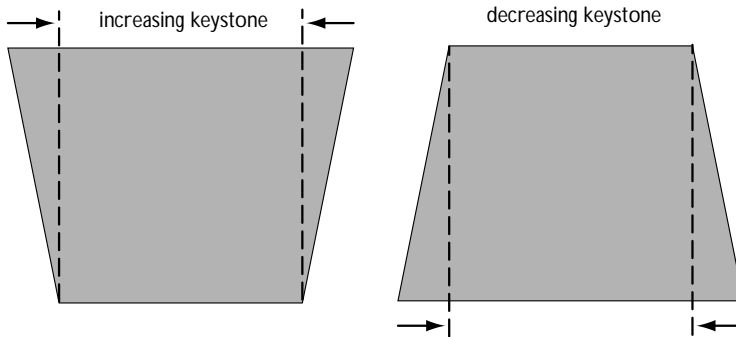

FIGURE 12

Adjusting the keystone

Forward/back buttons (remote only)

These buttons act like the page up and page down buttons on your computer's keyboard. You can use them to advance through a slide show in PowerPoint™ presentations. To use this feature, you must connect the USB mouse connector on the computer cable to your computer. See page 7 for details.

Up/down arrow buttons ^ v

Use these buttons to navigate through and make adjustments to the on-screen menus. See "Using the On-Screen Menus" on page 20 for details.



NOTE: Some menu items may be grayed out (dimmed) at certain times. This indicates the item is not applicable to your setup or the item is not enabled until another selection is made.

Using the On-Screen Menus

The projector has menus that allow you to make image adjustments and change a variety of settings. These adjustments aren't available directly from the keypad.

To open the on-screen menus, press the **menu/select** button on the keypad or remote. (The menus automatically close after 30 seconds if no buttons are pressed.) This displays the Main menu and changes the source and reset buttons on the keypad to menu navigation buttons. Press the **∨** button to move the cursor down and press the **∧** button to move the cursor up. The selected menu is highlighted.



FIGURE 13

Main menu

To change a menu setting, use the up and down arrow buttons to move the cursor up and down to the item you want to change (the selected item is highlighted), then press **menu/select**. When an item is selected, its button appears depressed to provide a visual indication of selection. Use the up and down arrows to adjust the setting or turn it on and off. Press **menu/select** when you are done. Press the up and down arrows to move to another setting. When you have completed your adjustments, navigate to Exit, then press **menu/select**. You are returned to the top of the Main menu. Press **menu/select** again to exit the Main menu, or navigate to another submenu.

Display Menu

To access the Display menu settings, press the **menu/select** button to display the Main menu, press the down arrow to highlight Display, then press **menu/select** again to access the Display menu.

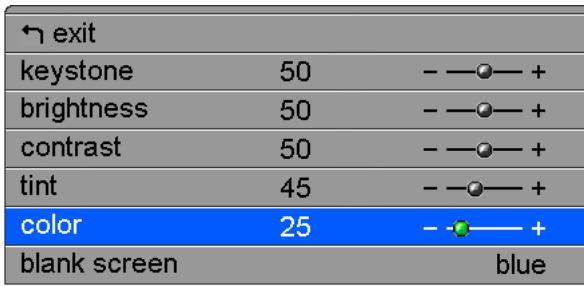

FIGURE 14

Display menu

Keystone

This option helps to keep the image square as the angle of projection is changed. Use this feature to adjust the image vertically and make a squarer image. See page 19 for details on keystone adjustments.

- 1 Press the down button to highlight Keystone, then press **menu/select**. Use the up and down arrows to adjust the keystone setting. Press **menu/select** to accept your changes.

Brightness

Adjusting the brightness changes the intensity of the image.

- 1 Use the up and down arrows to highlight Brightness, press **menu/select**, use the arrows to adjust the brightness, then press **menu/select** to accept your changes.



NOTE: *The color setting applies to video sources only. The tint setting applies to NTSC video sources only.*

Contrast

The contrast controls the degree of difference between the lightest and darkest parts of the picture. Adjusting the contrast changes the amount of black and white in the image.

- 1 Use the up and down arrows to highlight Contrast, press **menu/select**, use the arrows to adjust the contrast, then press **menu/select** to accept your changes.

Tint

The tint adjusts the red-green color balance in the projected image.

- 1 Use the up and down arrows to highlight Tint, press **menu/select**, use the arrows to adjust the tint, then press **menu/select** to accept your changes.

Color

The color setting adjusts a video image from black and white to fully saturated color.

- 1 Use the up and down arrows to highlight Color, press **menu/select**, use the arrows to adjust the color, then press **menu/select** to accept your changes.

Blank screen

Blank Screen determines what color is displayed when there is no active source and when the projector is in standby.

- 1 Use the up and down arrows to highlight Blank screen, press **menu/select**, use the arrows to cycle through the options blue, black, and white, then press **menu/select** to accept your selection.

Image Menu for Computer Sources

To access the Image menu settings, press the **menu/select** button to display the Main menu, press the down arrow to highlight Image, then press **menu/select** again to access the Image menu.

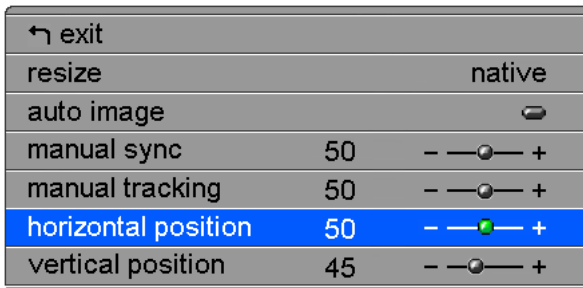

FIGURE 15

Image menu for computer sources

Resize

Resize allows you to select from among four different re-sizing options. The default is **Standard**, which resizes the image from its original version to fit a standard 4x3 aspect ratio screen. **Wide-screen Letterbox** preserves the 16x9 aspect ratio of the original theater version, but the image is placed in a 4x3 space, so black bars appear at the top and bottom of the image. **Enhanced Wide-screen** also preserves the aspect ratio of the original theater version and is designed to be used with content that is Enhanced for Widescreen TVs. This option yields more detail than Widescreen Letterbox. **Native** displays the image with no resizing.

Highlight **Resize**, press **menu/select**, use the up or down arrow buttons to cycle through the options, then press **menu/select** to select.

Auto Image

The projector automatically adjusts tracking, signal synchronization and vertical and horizontal position for most computers. If you want to adjust these features manually, you must turn off **Auto image** first.

Highlight **Auto image**, press **menu/select**, then press the up or down arrow buttons to turn this feature off and on.

Manual Sync

The projector adjusts signal synchronization automatically for most computers. But if the projected computer image looks fuzzy or streaked, try turning **Auto image** off then back on again. If the image still looks bad, try adjusting the signal synchronization manually:

- 1 Turn Auto Image off.
- 2 Highlight Manual sync, press **menu/select**, use the arrow buttons to adjust Manual sync until the image is sharp and free of streaks, then press **menu/select**.

Manual Tracking

The projector adjusts tracking automatically to match the video signal from your computer. However, if the display shows evenly spaced, fuzzy, vertical lines or if the projected image is too wide or too narrow for the screen, try turning **Auto Image** off then back on again. If the image is still bad, try adjusting the tracking manually:

- 1 Turn Auto image off.
- 2 Highlight Manual tracking, press **menu/select**, use the arrow buttons to adjust Manual tracking until the fuzzy vertical bars are gone, then press **menu/select**.

Horizontal Position

Follow these steps to manually adjust the horizontal position:

- 1 Turn Auto image off.
- 2 Highlight Horizontal position, press **menu/select**, use the arrow buttons to adjust the Horizontal position, then press **menu/select**.

Positioning adjustments are saved when you turn off the projector.

Vertical Position

Follow these steps to manually adjust the vertical position.

- 1 Turn Auto image off.
- 2 Highlight Vertical position, press **menu/select**, use the arrow buttons to adjust the Vertical position, then press **menu/select**.

Positioning adjustments are saved when you turn off the projector.



NOTE: The **Manual Sync**, **Manual Tracking**, **Horizontal Position** and **Vertical Position**

options are available only for analog computer sources. The projector sets these options automatically for digital computer and video sources, with no manual override.

Image Menu for Video Sources

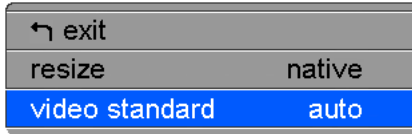

FIGURE 16

Image menu for video sources

Resize

Resize allows you to select from among four different re-sizing options. The default is **Standard**, which resizes the image from its original version to fit a standard 4x3 aspect ratio screen. **Wide-screen Letterbox** preserves the 16x9 aspect ratio of the original theater version, but the image is placed in a 4x3 space, so black bars appear at the top and bottom of the image. **Enhanced Wide-screen** also preserves the aspect ratio of the original theater version and is designed to be used with content that is Enhanced for Widescreen TVs. This option yields more detail than Widescreen Letterbox. **Native** displays the image with no resizing.

Highlight **Resize**, press **menu/select**, use the up or down arrows to cycle through the options, then press **menu/select**.

Video Standard (video sources only)

When Video is set to Auto, the projector attempts to pick the video standard (NTSC, NTSC 4.43, PAL, or SECAM) automatically based on the input signal it receives. (The video standard options may vary depending on your region of the world.) If the projector is unable to detect the correct standard, the colors might not look right or the image might appear “torn.” If this happens, manually select a video standard.

Highlight **Video standard**, press **menu/select**, use the up or down arrows to cycle through the options, then press **menu/select** to select.

Control Menu

To access the Control menu settings, press the **menu/select** button to display the Main menu, press the down arrow to highlight Control, then press **menu/select** again to access the Control menu.

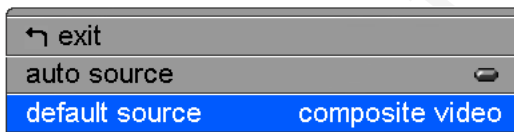

FIGURE 17

Control menu

Auto Source

When this feature is On, the projector automatically finds the active source, checking the default source first. When this feature is Off, the projector defaults to the source selected in Default Source. To display another source, you must manually select one by pressing the **source** button on the keypad or the **data** or **video** button on the remote.

Highlight **Auto source**, press **menu/select**, then press the up or down arrow buttons to turn this feature off and on.

Default Source

This determines which source the projector checks first for active video during power-up. Select among Data-Analog, Data-Digital, composite video, and S-Video.

Highlight **Default source**, press **menu/select**, use the up or down arrows to cycle through the options, then press **menu/select** to select.

Advanced Menu

To access the Advanced menu settings, press the **menu/select** button to display the Main menu, press the down arrow to highlight Advanced, then press **menu/select** again to access the Advanced menu.

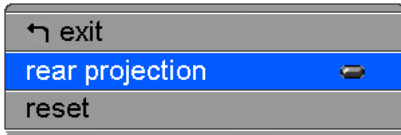

FIGURE 18

Advanced menu

Rear Projection

When you turn **Rear Projection** on, the projector reverses the image so you can project from behind a translucent screen.

Highlight **Rear Projection**, press **menu/select**, then press the up or down arrow buttons to turn this feature off and on.

Reset

Highlight Reset then press **menu/select** to reset the options in the menus (except Language, Video Standard, and Rear Projection) to their original settings.

Language Menu



FIGURE 19

Language menu

You can display the on-screen menus in English, French, German, Spanish, Chinese or Japanese.

- 1 Press the **menu/select** button to display the Main menu, press the arrow buttons to highlight Language, then press **menu/select** again to access the Language menu.
- 2 Press the arrow buttons to highlight the desired language, then press **menu/select**. Press **menu/select** to exit this menu and return to the Main menu.

Status Menu

This is a read-only menu for informational purposes. To display the Status menu, highlight Status from the Main menu, then press menu/select.

↵ exit	
lamp hours used	39
computer resolution	1024 x 768 – 75Hz
source	data-analog
version	111111

FIGURE 20

Status menu

Lamp hours used

Indicates how many hours the current lamp has been in use. The counter starts at zero hours and counts each hour the lamp is in use. Replace the bulb when the brightness is no longer acceptable. See “Replacing the Projection Lamp” on page 31 for details.

Computer resolution

Shows your computer’s resolution setting. To change this, go to your computer’s Control Panel and adjust the resolution in the Display tab. See your computer’s user’s guide for details.

Source

Indicates the active source, Data-Analog, Data-Digital, Composite video, or S-video.

Version

Indicates the projector’s software version. This information is useful when contacting Technical Support.

MAINTENANCE & TROUBLESHOOTING

This section describes how to:

- clean the lens
- replace the lamp module
- clean the projection lamp filter screens
- replace the batteries in the remote
- use the security lock feature
- troubleshoot the projector

Cleaning the Lens

Follow these steps to clean the projection lens:

- 1 Apply a non-abrasive camera lens cleaner to a soft, dry cloth.
 - Avoid using an excessive amount of cleaner, and don't apply the cleaner directly to the lens.
 - Abrasive cleaners, solvents or other harsh chemicals might scratch the lens.
- 2 Lightly wipe the cleaning cloth over the lens in a circular motion.
- 3 If you don't intend to use the projector immediately, replace the lens cap.

Replacing the Projection Lamp

The lamp hour counter in the Status menu counts the number of hours the lamp has been in use. Change the lamp when the brightness is no longer acceptable. You can order new lamp modules from your Dukane dealer. See "Accessories" on page 42 for information.

Follow these steps to replace the projection lamp:

- 1 Turn off the projector and unplug the power cord.
- 2 Wait 30 minutes to allow the projector to cool thoroughly.



.....
WARNING: To avoid burns, allow the projector to cool for at least 30 minutes before you open the lamp access grill. Never extract the lamp module while the projector is operating.



WARNING: Be extremely careful when removing the lamp module. In the unlikely event that the bulb ruptures, small glass fragments may be generated. The lamp module is designed to contain these fragments, but use caution when removing the lamp module.

- 3 Insert a small screwdriver or other flat object into the slot near the front of the projector. Slide the screwdriver toward the back of the projector to disengage the lamp access grill, then slide the lamp access grill off (away from the lens).

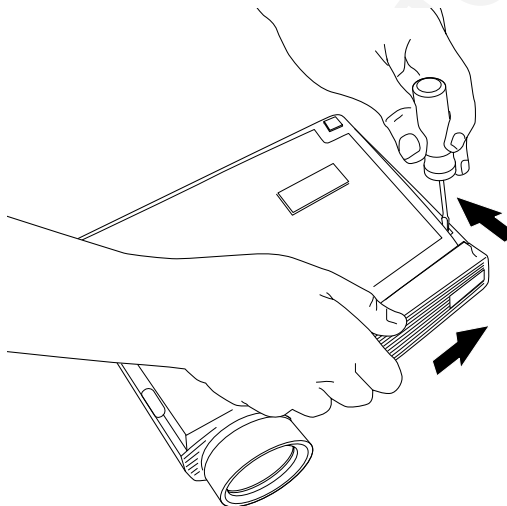

FIGURE 26
Disengaging and removing the lamp access grill



CAUTION: Never operate the projector with the lamp access grill removed. This disrupts the air flow and causes the projector to overheat.

- 4 Pull the yellow tab on the lamp module.

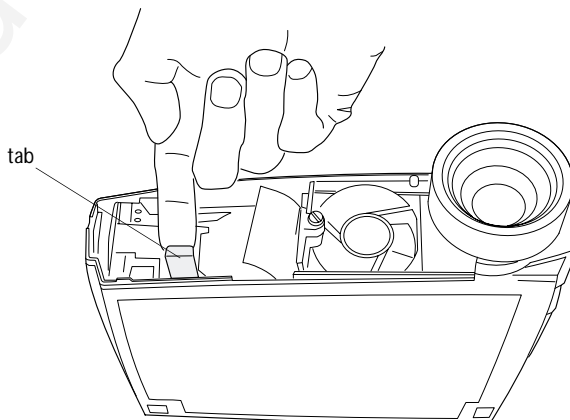

FIGURE 27
Pulling the tab on the lamp module

5 Loosen the captive screw on the lamp module.

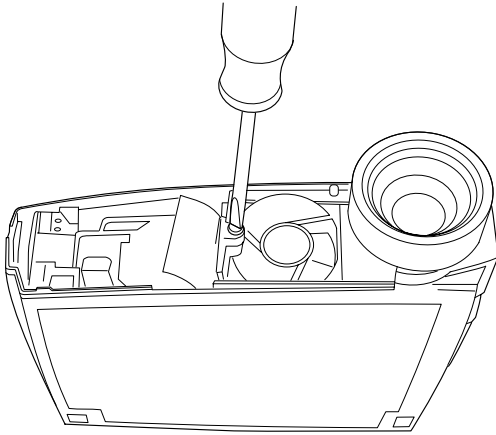

FIGURE 28

Loosening the screw on the lamp module

6 Grasp the pull tab to pull the lamp module out. Dispose of the lamp module in an environmentally proper manner.

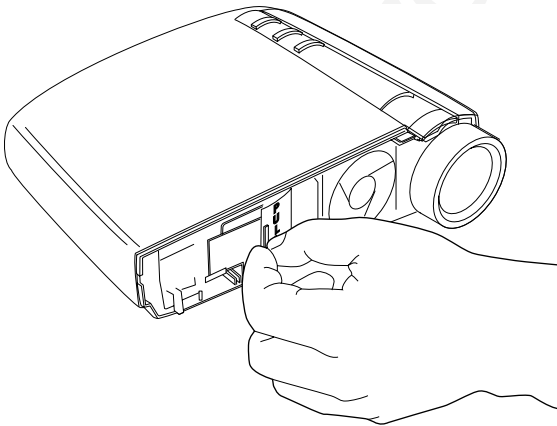

FIGURE 29

Removing the lamp module



WARNING: Do not drop the lamp module or touch the glass bulb! The glass may shatter and cause injury.

- 7 Install the new lamp module.
- 8 Tighten the screw on the outside of the module.
- 9 Press the yellow tab to reconnect the lamp module.
- 10 Replace the lamp access grill by lining up the ribs on the grill with the marks on the bottom case and sliding the grill in the direction of the arrows on the bottom case.
- 11 Plug in the power cord and press the Power switch to turn the projector back on.
- 12 To reset the lamp hour counter in the Status menu, press and hold the **reset** button, then press the **menu/select** button (while still holding down the **reset** button) for 10 seconds. Verify that the counter was reset by pressing the **menu/select** button and viewing the counter in the Status menu. See page 29 for details on the Status menu.

Cleaning the Projection Lamp Filter Screens

In dirty or dusty environments, the dust filter screens on the lamp module can become clogged, causing high temperatures inside the lamp module. These high temperatures can cause premature lamp failure. Routine maintenance to remove dust and dirt from the screens lowers the lamp operating temperature and prolongs lamp life. To maximize lamp life you may want to clean the screen every 250 hours.

- 1 Remove the lamp module. Refer to “Replacing the Projection Lamp” on page 31 for instructions.
- 2 Examine the dust filter screens on each side of the lamp module. If necessary, use compressed or canned air to clean the screens. Then use a cotton swab dipped in isopropyl alcohol to lightly wipe each screen. After you've wiped each screen, use the compressed or canned air to blow away remaining contaminants.
- 3 Before you replace the lamp, use the compressed or canned air to clean the lamp housing in the projector.
- 4 Replace the lamp and lamp door.

Replacing the Batteries in the Remote Control

The life of the batteries depends on how often and how long you use the remote. Symptoms of low battery charge include erratic responses when using the remote and a reduced range of operation.

Follow these steps to replace the batteries:

- 1 Turn the remote face down in your hand.
- 2 Push the tab on the battery door toward the top of the remote and lift the door off.
- 3 Remove the old batteries and dispose of them in an environmentally proper manner.
- 4 Install two new AAA alkaline batteries. Make sure you install each in the correct direction.
- 5 Insert the hooks on the battery door into the remote and press the tab to re-install the door.

Using the Security Lock

The projector has a security connector for use with a PC Guardian Cable Lock System (Figure 30). See “Optional Accessories” on page 43 for ordering information. Refer to the information that came with the lock for instructions on how to use it to secure the projector.



NOTE: The lamp cannot be removed while the security lock is attached.

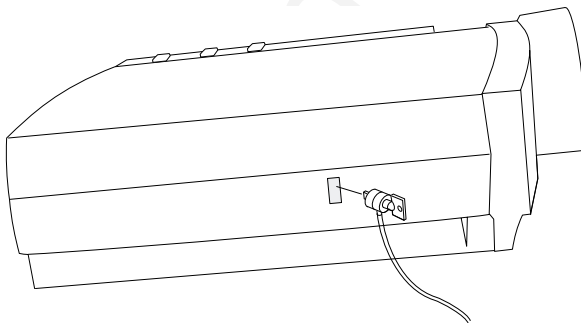

FIGURE 30

Installing the security lock

Troubleshooting

Problem: The projector is not running

- Make sure that the power cord is properly connected to a fully functional AC electrical outlet. Make sure that the power cord is also properly connected to the projector.
- If the projector is plugged into a power strip, make sure the power strip is turned on.
- Make sure the projector is turned on.

Problem: Projector is running, but nothing appears on projection screen

- Make sure you have removed the lens cap on the projection lens at the front of the projector.
- Check the projector's lamp to ensure that it is securely connected in the lamp module. Make sure the lamp access grill is installed. See "Replacing the Projection Lamp" on page 31.

Problem: Only the start-up screen displays

- Verify that the cables are connected correctly. See page 7 for connection procedures.
- Make sure that the cables do not have any bent pins.
- Verify that the proper input source is connected. See "Source (keypad only) or Data and Video (remote only)" on page 18.
- You might need to turn everything off and power up the equipment again in the proper order. Refer to your computer's documentation to determine the correct order.
- Make sure your laptop's external video port is turned on. See the "Portable and Laptop Activation Chart" on page 44 or your computer's manual for details.
- Make sure your computer's video board is installed and configured correctly.
- Make sure your computer has a compatible video board. The projector isn't CGA or EGA compatible.

If you're using Windows 98:

- 1 Open "My Computer" icon, the Control Panel folder and then the Display icon.
- 2 Click the Settings tab.
- 3 Verify that the Desktop area is set to 1280x1024 or less.

Problem: Color or text not being projected

- You might need to adjust the brightness up or down until the text is visible. Refer to "Brightness" on page 21 for more information.

Problem: The screen resolution is not right

- Make sure the computer's video card is set for a resolution of no greater than 1280x1024.

Problem: Image isn't centered on the screen

- Move the projector to reposition the image.
- Reposition the image using the menu. Refer to "Horizontal Position" on page 24 and "Vertical Position" on page 24.
- Be sure the projector is at a 90 degree angle to the screen.

Problem: Image is too wide or narrow for screen

- Adjust the zoom or projector placement.
- Adjust the resolution of your video card if it's greater than 1280x1024.

Problem: Image is out of focus

- Turn the projection lens to focus the image.
- Make sure the projection screen is at least 5 feet (1.5 m) from the projector.
- Check the projection lens to see if it needs cleaning.

Problem: Image and menus are reversed left to right

- Rear projection mode is probably turned on. Turn Rear Projection off in the Controls menu. The image should immediately return to forward projection. See "Rear Projection" on page 27.

Problem: the projector displays vertical lines, “bleeding” or spots

- Adjust the brightness. See “Brightness” on page 21.
- Check the projection lens to see if it needs cleaning.

Problem: Image is “noisy” or streaked

Try these steps in this order.

- 1 Deactivate the screen saver on your computer.
 - 2 Turn **Auto Image** off and then back on again. See “Auto Image” on page 23.
 - 3 Turn **Auto Image** off and adjust the synchronization and tracking manually to find an optimal setting. See “Manual Sync” on page 24 and “Manual Tracking” on page 24.
- The problem could be with your computer’s video card. If possible, connect a different computer.

Problem: Projected colors don’t match the computer or video player’s colors

- Just as there are differences in the displays of different monitors, there are often differences between the computer image and the projected image. Adjust the brightness, tint and/or contrast from the Display menu. See “Brightness” on page 21, “Tint” on page 22 and “Contrast” on page 22.

Problem: Lamp seems to be getting dimmer

- The lamp begins to lose brightness when it has been in use for a long time. Replace the lamp as described in “Replacing the Projection Lamp” on page 31.

Problem: Lamp shuts off

- A minor power surge may cause the lamp to shut off. Unplug the projector, wait at least a minute, then plug it back in.
- Make sure the vents are not blocked.

Before calling your dealer or Dukane Technical Support for assistance, please have the following information available:

- the projector's serial number (located on the bottom label)
- the resolution of your computer.

Call Dukane Technical Support at: **630-584-2300 or Toll-Free at: 1 800-676-2487**

APPENDIX

Specifications

The projector must be operated and stored within the temperature and humidity ranges specified.

Temperature

Operating	50 to 104° F (10 to 40° C) at sea level 50 to 95° F (10 to 35° C) at 10,000 feet
Non-operating	-4 to 158° F (-20 to 70° C)

Altitude

Operating	0 to 10,000 feet (3,048 meters)
Non-operating	0 to 20,000 feet (6,096 meters)

Humidity

Operating and non-oper.	10% to 95% relative humidity, non-condensing
-------------------------	--

Dimensions

6.7 x 8.6 x 2 inches (16.9 x 21.9 x 5.1 cm)

Weight

3.0 lbs. (1.36 kg) unpacked

Optics

Focus Range	4.9 - 16.4 feet (1.5-5 m)
-------------	---------------------------

Lamp

Type	120-watt UHP lamp
------	-------------------

Input Power Requirements

100-120VAC 2A; 50/60Hz
200-240VAC 1A; 50Hz

Accessories

Standard Accessories (ship with the projector)

User's Guide

Soft Case

Shipping Box

Analog Computer Cable 6 ft (1.8 m)

Composite RCA Video Cable 6 ft (1.8 m)

S-video Cable 6 ft (1.8 m)

Remote

Projection Lamp Module (included in projector)

Lens Cap

Power Cord





NOTE: Use only Dukane approved accessories. Other products have not been tested with the projector.

Optional Accessories

For a complete listing of Optional Accessories:

- Contact your local Dukane Dealer
- Contact Dukane Audio Visual Products Division at:
1-800-676-2485/2486
- Check out our web-site at: www.dukane.com/av

Portable and Laptop Activation Chart

Many laptop computers do not automatically turn on their external video port when a projector is connected. Activation commands for some laptop computers are listed in the following table. (If your computer is not listed or the given command does not work, refer to the computer's documentation for the appropriate command.) On many laptops, the activation function key is labeled with an icon, for example / or the text CRT/LCD.



NOTE: Usually, pressing the key commands once activates the external video port, pressing it again activates both the external and internal ports, and pressing it a third time activates the internal port. Refer to your computer's documentation for details on your specific model.

Computer	Key command to activate port	Key command to de-activate port
Acer	Ctrl-Alt-Esc (for setup)	Ctrl-Alt-Esc (for setup)
AST* **	FN-D or Ctrl-D Ctrl-FN-D FN-F5 type from A:/VGA/CRT FN-F12	FN-D or Ctrl-D Ctrl-FN-D FN-F5 type from A:/VGA/CRT FN-F12
AMS	FN-F2	FN-F2
AMT	setup screen	setup screen
AT&T	FN-F3 FN-F6	FN-F3 FN-F6
Advanced Logic Research	Ctrl-Alt-V	Ctrl-Alt-V
Altima	Shift-Ctrl-Alt-C setup VGA/ Conf.Simulscan	Shift-Ctrl-Alt-L setup VGA/ Conf.Simulscan
Ambra**	FN-F12 FN-F5 F2/Choose Option/F5	FN-F12 FN-F5 F2/Choose Option/F5
Amrel* **	setup menu Shift-Ctrl-D	setup menu Shift-Ctrl-D
Apple	see Mac Portable and Mac PowerBook	
Aspen	automatic	automatic
Award	FN-F6	FN-F6
BCC*	automatic	reboot computer

Computer	Key command to activate port	Key command to de-activate port
Bondwell	LCD or CRT options after bootup	reboot for LCD or CRT options to appear
Chaplet**	setup screen FN-F6 FN-F4	setup screen FN-F6 FN-F4
Chembook	FN-F6	FN-F6
Commax	Ctrl-Alt-#6	Ctrl-Alt-#5
Compaq* **	Ctrl-Alt-< FN-F4 automatic mode/? (for setup option)	Ctrl-Alt-> FN-F4 automatic mode/? (for setup option)
Compuadd* **	automatic Alt-F for screen setup option	automatic Alt-F for screen setup option
Data General	Ctrl-Alt-Command	Ctrl-Alt-Command
Data General Walkabout	2 CRT/X at DOS prompt	reboot
Datavue	Ctrl-Shift-M	Ctrl-Shift-M
DEC**	FN-F5 FN-F4	FN-F5 FN-F4
Dell**	Ctrl-Alt-< Ctrl-Alt-F10 FN-F8 (CRT/LCD) FN-D FN-F12	Ctrl-Alt-> Ctrl-Alt-F10 FN-F8 FN-D FN-F12
Digital*	automatic FN-F2	reboot FN-F2
Dolch	dip switch to CRT	dip switch to LCD
Epson	dip switch to CRT	dip switch to LCD
Everex*	setup screen option	setup screen option
For-A	Ctrl-Alt-Shift-C	Ctrl-Shift-Alt-L
Fujitsu	FN-F10	

Computer	Key command to activate port	Key command to de-activate port
Gateway	FN-F3 FN-F1/FN-F1 again simultaneous	FN-F3 FN-F1
Grid* **	FN-F2, choose auto or simultaneous Ctrl-Alt-Tab	FN-F2 Ctrl-Alt-Tab
Hitachi	FN-F7	FN-F7
Honeywell	FN-F10	FN-F10
Hyundai	setup screen option	setup screen option
IBM 970*	automatic	warm reboot
IBM ThinkPad**	reboot, enter setup menu FN-F7, select choice from setup menu FN-F1, select choice FN-F5, select choice PS/2 SC select choice (CRT, LCD, etc.)	FN-F2
Infotel	FN-F12	FN-F12
Kaypro	boot up, monitor plugged in	unplug monitor
Kris Tech	FN-F8	FN-F8
Leading Edge	FN-T	FN-T
Mac Portable 100	no video port: not compatible	
Mac PowerBook	no video port: requires a 3rd-party interface	
140, 145, 150, 170	no video port: requires a 3rd-party interface	
160, 165, 180, 520, 540, 5300	Control Panel folder, PowerBook Display folder; Activate Video Mirroring	warm reboot
210, 230, 250, 270, 280, 2300	requires Apple Docking Station or Mini Dock	
Magitronic	FN-F4	FN-F4
Mastersport	FN-F2	FN-F1

Computer	Key command to activate port	Key command to de-activate port
Micro Express*	automatic	warm reboot
Micron	FN-F2	FN-F2
Microslate*	automatic	warm reboot
Mitsubishi	SW2 On-Off-Off-Off	SW2 Off-On-On-On
NCR	setup screen option	setup screen option
NEC* **	setup screen option CRT at the DOS prompt FN-F3	setup screen option LCD at the DOS prompt FN-F3
Olivetti*	automatic FN-O/*	automatic FN-O/*
Packard Bell* **	FN-F0 Ctrl-Alt-<	FN-F0 Ctrl-Alt->
Panasonic	FN-F2	FN-F2
Prostar	Ctrl-Alt-S at bootup	Ctrl-Alt-S at bootup
Samsung*	setup screen option	setup screen option
Sanyo	setup screen option	setup screen option
Sharp	dip switch to CRT	dip switch to LCD
Sun SPARC-Dataview	Ctrl-Shift-M	Ctrl-Shift-M
Tandy**	Ctrl-Alt-Insert setup screen option	Ctrl-Alt-Insert setup screen option
Tangent	FN-F5	FN-F5
Texas Instruments*	setup screen option	setup screen option
Top-Link* **	setup screen option FN-F6	setup screen option FN-F6
Toshiba* **	Ctrl-Alt-End FN-End FN-F5 setup screen option	Ctrl-Alt-Home FN-Home FN-F5 setup screen option
Twinhead*	FN-F7 FN-F5 Automatic	FN-F7 FN-F5 Automatic
WinBook	Ctrl-Alt-F10	Ctrl-Alt-F10

Computer	Key command to activate port	Key command to de-activate port
Wyse	software driven	software driven
Zenith**	FN-F10 FN-F2 FN-F1	FN-F10 FN-F2 FN-F1
Zeos**	Ctrl-Shift-D FN-F1	Ctrl-Shift-D FN-F1

* These manufacturers have models that automatically send video to the external CRT port when some type of display device is attached.

** These manufacturers offer more than one key command depending on the computer model.

Using Video Mirroring with a PowerBook Computer

When you turn video mirroring (called SimulScan in newer PowerBooks—see below) on, the projector displays the same information that appears on your PowerBook's built-in screen. When video mirroring is off, the projector acts like a separate display.

To turn on video mirroring for the first time:

- 1 Open the Monitors control panel; click on Monitor 2.
- 2 Set the number of colors you want.
- 3 Open the Control Strip, then click on the monitor icon.
- 4 Select "Turn Video Mirroring On."

Now you can turn video mirroring on and off from the Control Strip without having to open the Monitors control panel again.

When using video mirroring and high color graphics such as slide shows, the projected image occasionally might turn black and white. If this happens, perform the following steps:

- 1 Turn off video mirroring.
- 2 Open the Monitors control panel.
- 3 Move the white menu bar to Monitor 2 to set the projector as the primary monitor.
- 4 Restart the PowerBook.

Using SimulScan

Some newer PowerBooks display images on an external monitor or projector differently than previous ones. When using SimulScan, the projector displays the same information that appears on your PowerBook

To select SimulScan:

- 1 Open the Control Panel, then double-click Monitors and Sound.
- 2 In the Resolution list, choose the SimulScan mode, then click OK.
- 3 If this changes your display settings, a dialog box appears. Click OK to confirm the change.



Projected Image Size

NOTE: Use the graph and table to help you determine projected image sizes.

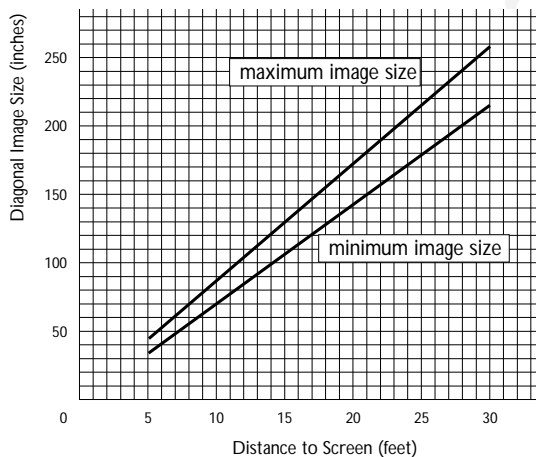

FIGURE 31

Projected image size

Table 1:
Range of distance to the screen for a given screen size

Diagonal Screen Size (inches)	Image Width (inches)	Distance to screen	
		Maximum distance (feet)	Minimum Distance (feet)
60	48	8.5	6.9
72	58	10.2	8.3
84	67	11.9	9.7
90	72	12.7	10.4
100	80	14.1	11.6

INDEX

A

- accessories, ordering 42, 43
- activation commands for laptop computers 43
 - puters 43
- adjusting
 - brightness 21
 - color 22
 - contrast 22
 - height of the projector 16
 - keystone 21
 - tint 22
- Advanced menu options
 - Rear projection 27
 - Reset 27
- altitude limits 41
- assistance. See Technical Support
- auto image 23
- auto source 26

B

- brightness, adjusting 21
- buttons on keypad
 - Menu/select 18
 - Reset 19
 - Source 18

C

- cables
 - computer cable 2, 6, 7
 - ordering 42
 - power 42
 - video 8
- cases, ordering 42
- centering the image 16, 24
- cleaning the lamp filter screens 34
- cleaning the projection lens 31
- color, adjusting 22
- colors
 - don't match monitor colors 38
 - not displayed 37
- compatibility
 - IBM-compatible 1
 - Macintosh 1
- computer cable 2, 6, 7
- computers
 - compatible 1
 - connecting 7
- connecting
 - computer 7
 - power cord 9
 - video player 8
- contrast, adjusting 22
- Control menu options
 - Auto source 26
 - Default Source 26

D

- Default Source 26
- Display menu options
 - Blank screen 22
 - Brightness 21
 - Color 22
 - Contrast 22
 - Keystone 21
 - Tint 22

displaying on-screen menus 18

E

- elevator button/foot 16

F

- focusing the image 15
- forward/back buttons 19
- fuzzy lines 24

H

- HDTV 1, 8, 22
- height adjustment 16

I

- IBM-compatible computers
 - compatibility 1
 - connecting 7
- image
 - adjusting 9, 15
 - centering 24
 - colors don't match computer's 38
 - focusing 15
 - fuzzy lines 24
 - has lines or spots 38
 - not centered 37
 - not displayed 36
 - out of focus 37
 - quality 37,38
 - resolution 1
 - reversed 27, 37
 - size 5, 51
 - streaked 38
 - too wide or too narrow 37
 - zooming 15
- Image menu options
 - Auto Image 23
 - Horiz. Position 24
 - Manual Sync 24
 - Manual Tracking 24
 - Resize 23
 - Vert. Position 24
 - Video Standard 25
- installing
 - drivers 9

K

- keypad 18
- keystone adjustment 19

L

- lamp
 - cleaning filter screens 34
 - ordering 42, 43
 - replacing 31
 - turns off unexpectedly 38
- lamp hour counter 29, 31, 42
- Language menu 28
- language, selecting for menus 28
- laptop computers
 - activation sequence to allow secondary display 44
 - compatibility 7
 - connecting 7
- LED 9, 18
- lens
 - cap 42
 - cleaning 31
- ImagePro 28A8747
 - cases 42
 - project from behind the screen 27
 - setting up 5
 - specifications 41
 - turning off 13
 - turning on 9

M

- Macintosh computers
 - compatibility 1
 - connecting 6
 - installing drivers 12
- maintenance 31
- menus. See on-screen menus
- monitor, projected colors don't match 38

N

- NTSC video 25

O

- on-screen menus
 - changing language of 28
 - displaying 20

P

- PAL video 25
- power cord
 - connecting 9
 - ordering 42
- power up sequence 9, 36
- PowerPoint slides, advancing 19
- project from behind the screen 27

R

- rear projection 27
- remote control
 - advancing PowerPoint slides with 19
 - replacing the batteries 35
 - using 17, 18
- replacing projection lamp module 31
- re-positioning the image on the screen 24
- Reset button 19
- resetting adjustments 19, 27
- resetting the lamp hour counter 34
- resizing the image 23
- resolution 1

S

- safety guidelines iii
- SECAM video 25
- security lock 35, 43
- shutting off the projector 13
- SimulScan, using with PowerBooks 49
- Source button 18
- specifications 41
- starting up the projector 9

- Status menu 29
- S-video, connecting 8

T

- Technical Support
 - in Europe 4
 - in Singapore 4
 - in USA 4
 - information to have on hand
 - before you call 39
- temperature limits 41
- text not visible 37
- tint, adjusting 22
- troubleshooting 36
- turning off the projector 13
- turning on the projector 9

V

- vertical lines displayed 24, 38
- video cable, connecting 8
- video mirroring on a PowerBook 49
- video resize 25
- video standard 25

W

- widescreen video 23, 25

Z

- zooming the image 15

LEGAL INFORMATION

FIVE-YEAR LIMITED WARRANTY

This Dukane LCD projector is warranted to the original purchaser for a period of five (5) years from the original purchase date - in normal use and service - against defects in material and workmanship. DUKANE CORPORATION EXPRESSLY DISCLAIMS ALL OTHER WARRANTIES OF MERCHANTABILITY AND FITNESS FOR A PARTICULAR PURPOSE.

During the warranty period, Dukane Corporation will repair or replace (at the manufacturer's option) any such defective parts (except for the lamp, which is subject to whatever warranties the manufacturer may provide) without charge to the purchaser for parts or labor when the product is returned, prepaid and insured, with proof-of-purchase date. This remedy is void if the product has been damaged by accident, unreasonable use, neglect, improper service or other causes not arising out of defects in material or workmanship.

Dukane Corporation disclaims all liability for incidental or consequential damage of any kind, including all damages arising out of any interruptions in operation of the product and all damages to software.

No person, firm, or representative is authorized to assume any obligation or to make any warranty on behalf of the Dukane Corporation other than as stated above.

**THIS LIMITED WARRANTY IS VALID FOR U.S.A AND CANADA.
FOR OTHER LOCATIONS, LOCAL WARRANTIES APPLY.**

SERVICE & REPAIR

For service and parts, contact the Dukane AV Service Department at 1 (800) 676-2487 within the USA or 1 (630) 584-2300 worldwide. If you would like to send a facsimile (FAX), dial 1 (630) 584-5156 worldwide.

When requesting warranty service, please have the sales receipt available along with the model name and serial number.

If it becomes necessary to return the projector, use the original packing material and box (if retained) or pack securely. Dukane Corporation will not be liable for any pick-up or delivery charges or any expenses incurred for service calls or service supplied by anyone other than the Dukane AV Service Department.

Dukane Corporation
Audio Visual Products Division
2900 Dukane Drive
St. Charles, IL 60174-3395
E-mail: avsales@dukane.com

Phone: (630) 584-2300
Orders: (800) 676-2485
Information: (800) 676-2486
Fax: (630) 584-5156
Parts & Service: (800) 676-2487
Fax: (630) 584-0984

Audio Visual Products

DUKANE

Part # 401-579-00

PLEASE READ

This manual is provided as a free service by Projector.com.

We are in no way responsible for the contents of the manual. We do not guarantee its accuracy and we do not make any claim of copyright. The copyright remains the property of their respective owners.

ABOUT PROJECTOR.COM

Projector.com (<http://www.projector.com>) is your review and buying guide resource for DLP and LCD video projectors.

Visit the site to read the latest projector news and reviews, read and comment on projector specifications, download user manuals and much more.